



Guangzhou Micro-shot Technology Co., Ltd

Inverted LED Fluorescence Attachment

**MI-BG-LED
User Manual**



Website: www.m-shot.com

Email: sales@m-shot.com

I. Components

No.	Name	Quantity	Unit
1	Attachment body	1	set
2	Power adapter	1	piece
3	3.0mm hex screwdriver	1	piece
4	M4X4 philip's head screw	4	piece

II. Specifications

B excitation group	EF 460-490nm (Tavg>94%) DM 505nm (505-1200nm, Tavg>93%) BF 510 nm (510-1200nm, Tavg>90%)
G excitation group	EF 510-550nm(Tavg>91%) DM 570nm(505-1200nm, Tavg>93%) BF 585nm (585-1200nm, Tavg>91%)
Light source	3W LED cold light
Observation	Fluorescence, bright field
Transfer mode	Pull-push at three positions (Blue, green, bright field)
Brightness adjustment	1.Continuous adjustment 2.100%, 75%, 50% brightness set
Input power	DC 4.2V 2A
Matched microscope	Olympus CKX41, MSHOT MF50

III Installation

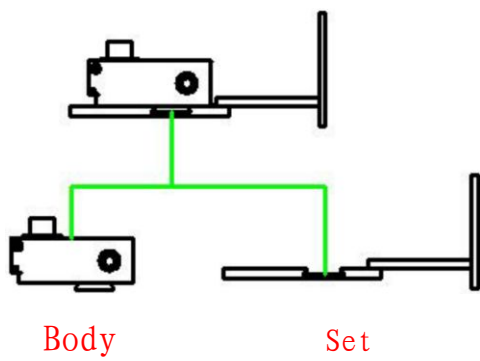

(Figure 1)

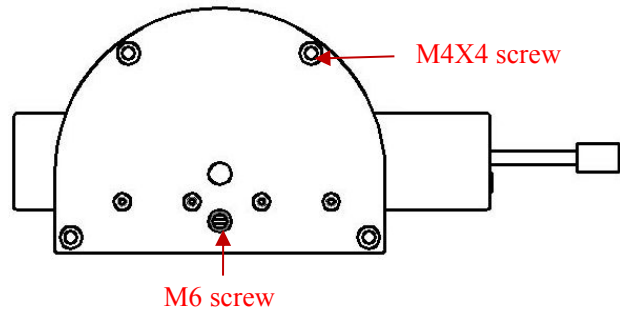

(Figure 2)

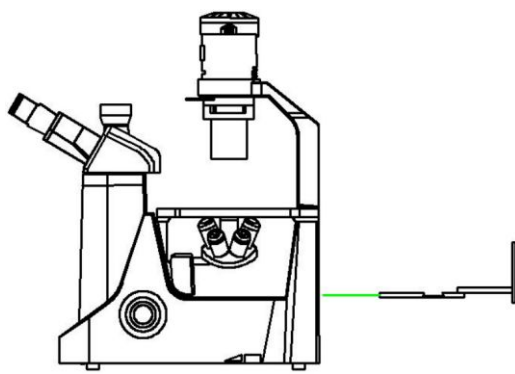

(Figure 3)

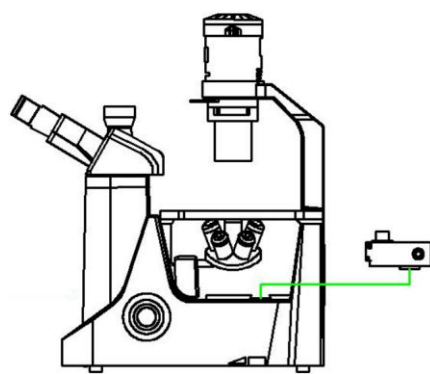

(Figure 4)

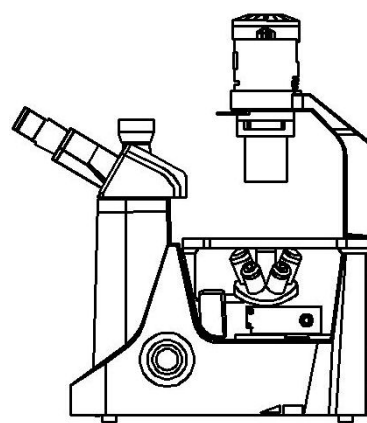

(Figure 5)

1. Inverted LED fluorescence attachment is consist of: the base and the body shown in Figure 1.
2. Use M3.0 hex screwdriver to loosen the M6 screws, shown in Figure 2.
3. Push in base of the attachment from the rear side of an inverted microscope, as shown in Figure 3. Use a Phillips screw tightening match M4X4 Phillips screws, the base is fixed on the microscope, screw holes as shown in Figure 2.
4. Push in the body align from the left Slide rails of the microscope, shown in Figure 4.
5. Use M3.0 hex screwdriver to tighten the M6 screws, as shown in Figure 2. Fished as Figure 5.

IV. Operation

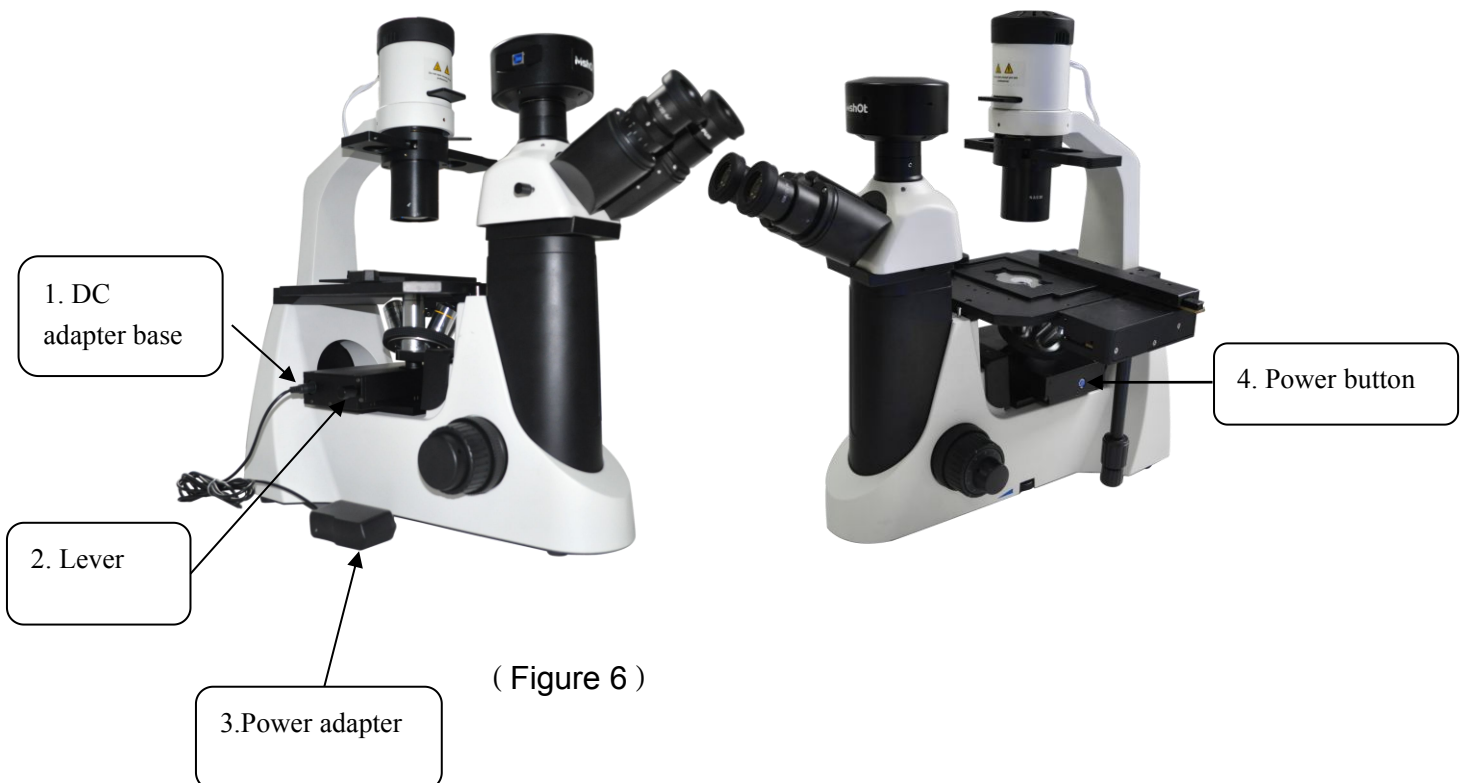

1. Components as Figure 6 (take MSHOT microscope as sample).
2. Power adapter (3 in the figure 6) one side connect to power, another side connect to the DC adapter base(1 in the figure 6) on the left side of the fluorescence attachment.
3. Press button (4 in the figure 6) on the right side of the fluorescence attachment.

The button opened default as the max brightness. The second time press, brightness set is 70%. The third press, brightness set is 50%. The fourth press, light off. Continuous pressing button, brightness is adjusting continuously.

4. Push or pull lever to change fluorescence filter cube among blue, green and bright field.

Push in lever is default of green excitation filter set, pull out lever half is for blue excitation filter set, fully pull out lever is for bright field.

(Note: Before fully pull out lever for bright field observation, please close the blue color power button (4 in the figure 6) first.